

The theory of structural interdependence

some suggestions for a new theoretical framework

Workshop on organizational design
EIASM, Brussel, April 16-17, 2007

Lucio Biggiero

University of L'aquila, biggiero@ec.univaq.it, ibiggier@luiss.it

Knownetlab Research Center www.knownetlab.it

An outline of building blocks of organization design theory

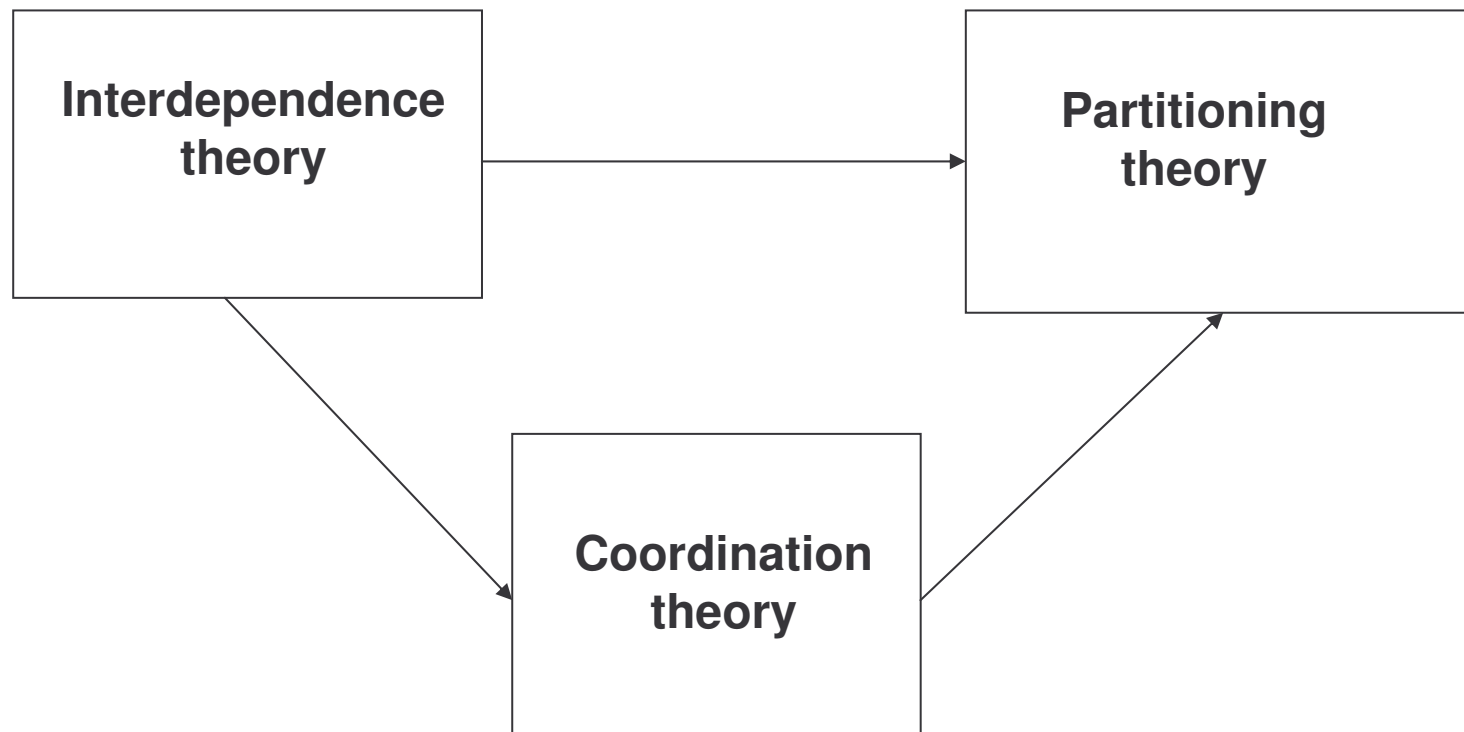

Main theoretical perspectives

Organization design theory

Economics:

- * Economic (mechanisms) design theory,

- * Complementarity (super-modularity) theory,

- * Contractualism-incentive theory,

- Transaction cost economics

Engineering design theory

Computational and complexity theory

Questions defining a theory of interdependence

- **How much complex is a given interdependence pattern?**
- **How much complex is a given (set of) connection(s) within a given interdependence pattern?**

Continue...

- **Among the determinants of interdependence, which one(s) does matter mostly? And in which specific (hopefully mathematically defined) way?**
- **How do the determinants of interdependence interact each other?**

Types of interdependence

- **Structural** (physical or abstract technology)
- **Behavioral** (socio-cognitive, psycho-social)
- **Informational** (knowledge- or communication-based)
- **Juridical-economic** (contractual- or cost-based)

Aims of interdependence theory

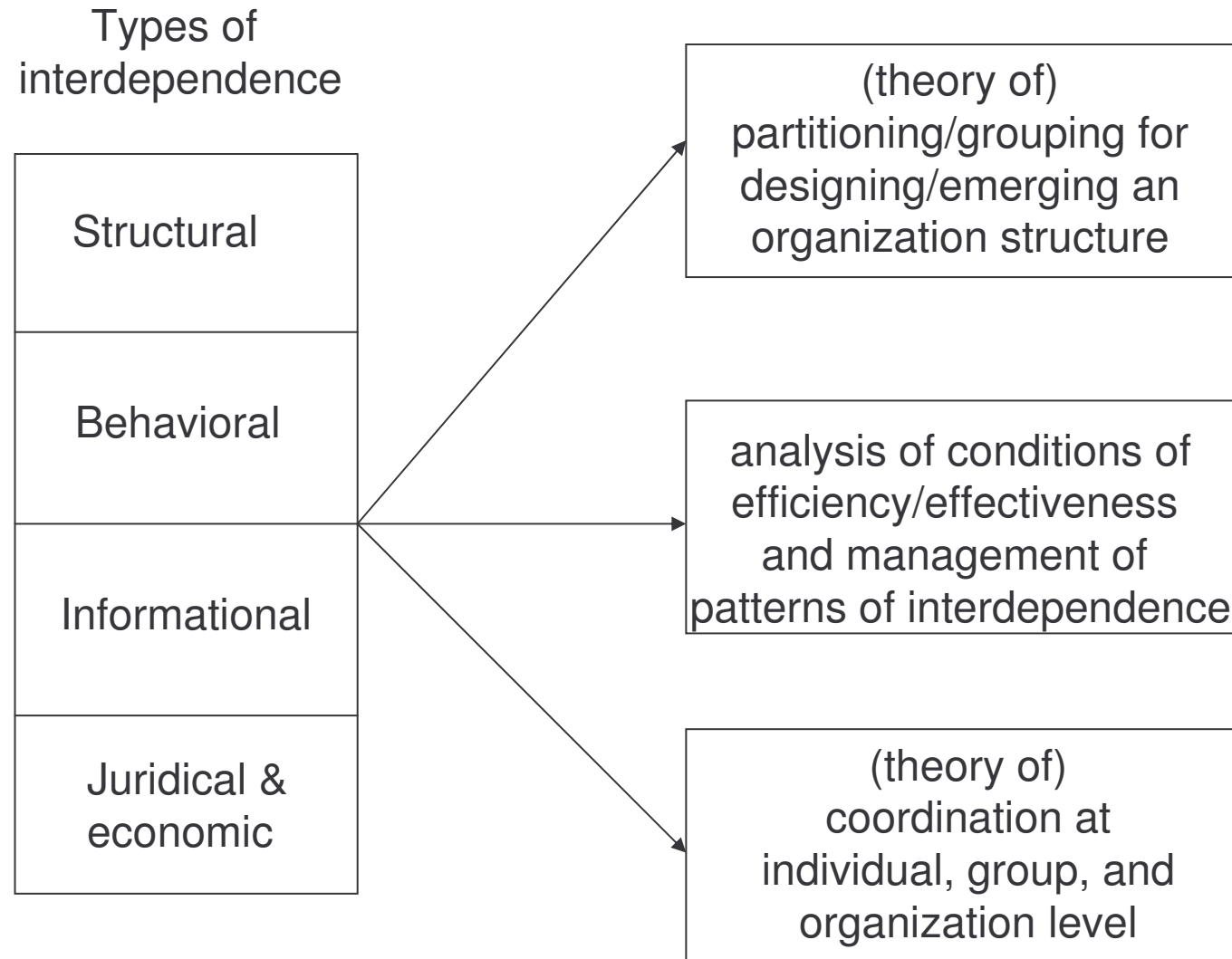

A set of tasks (elementary activities)

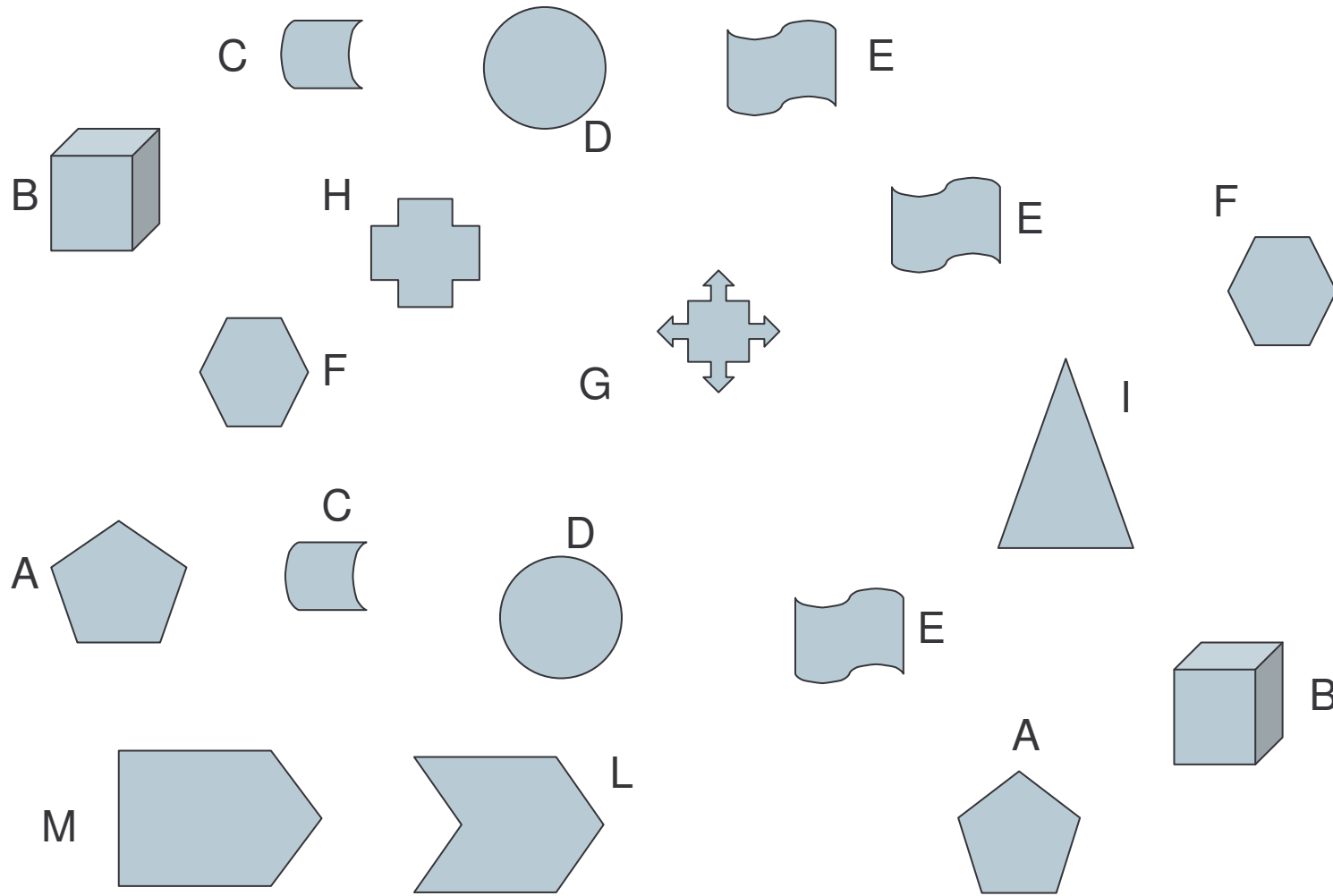

The generation of an interdependence pattern

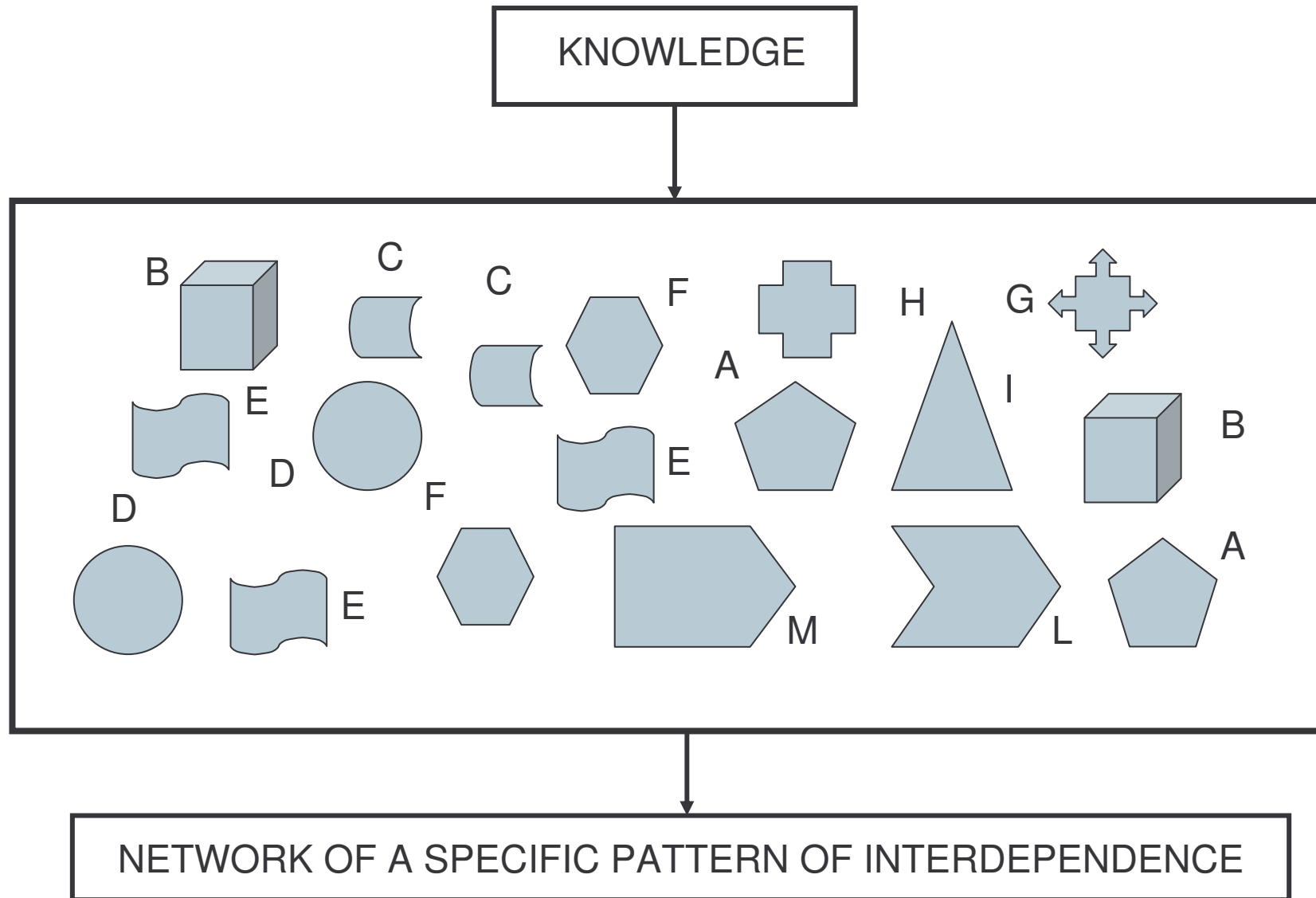

Technology as a pattern of structural interdependence

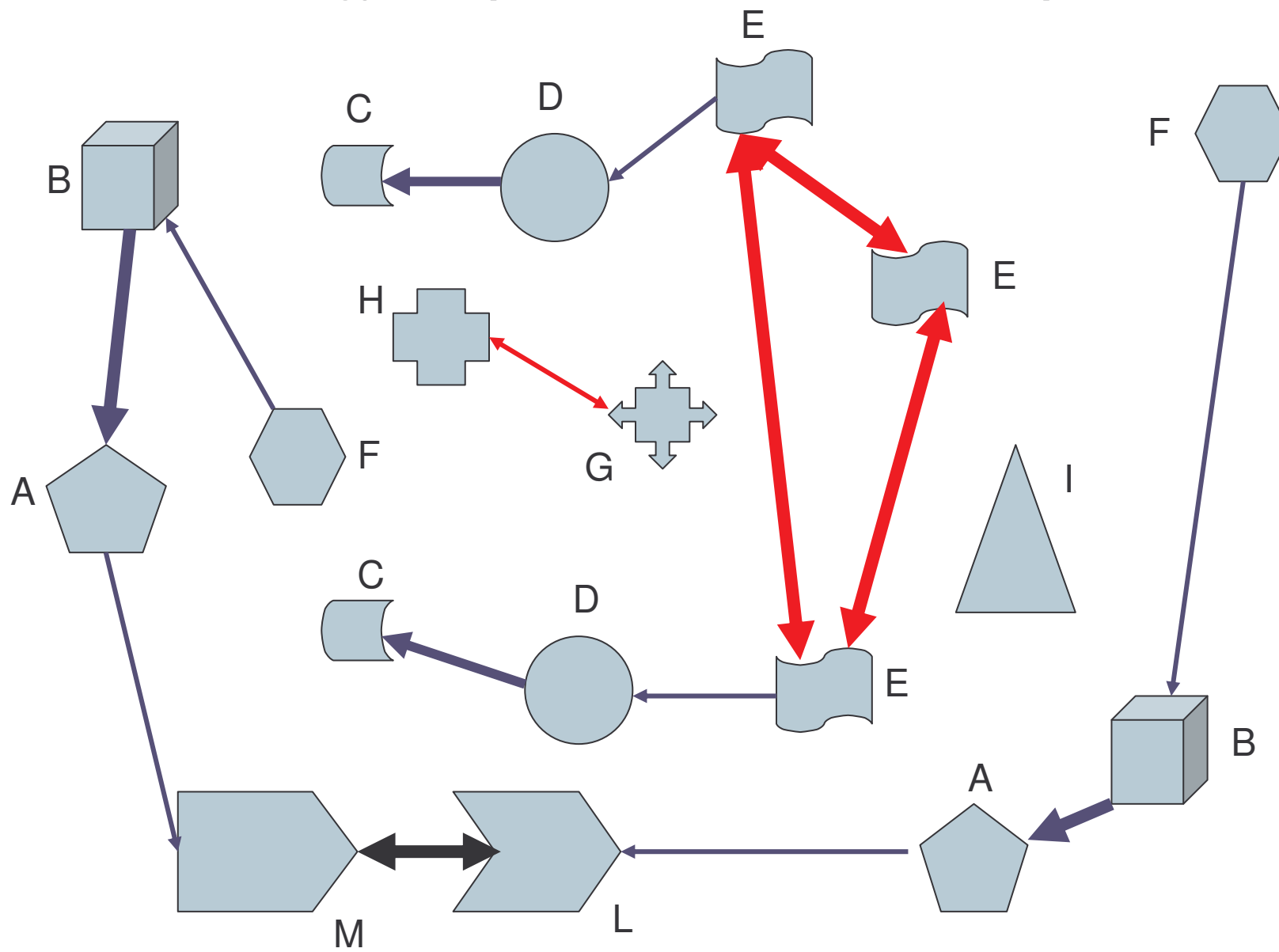

Multi-level theory

- Task
- Org unit
- Department
- Organization
- Population
- Community of populations

Multi-focus analysis

- **Network (whole pattern)**
- **Single connections (dyads)**
- **Single nodes (ego networks)**

Factors at network level

Questions:

- 1) Which is the degree of complexity of a given interdependence pattern?
- 2) How and how much does each factor affect the performance of the whole pattern?
- 3) How do factors interact one another?

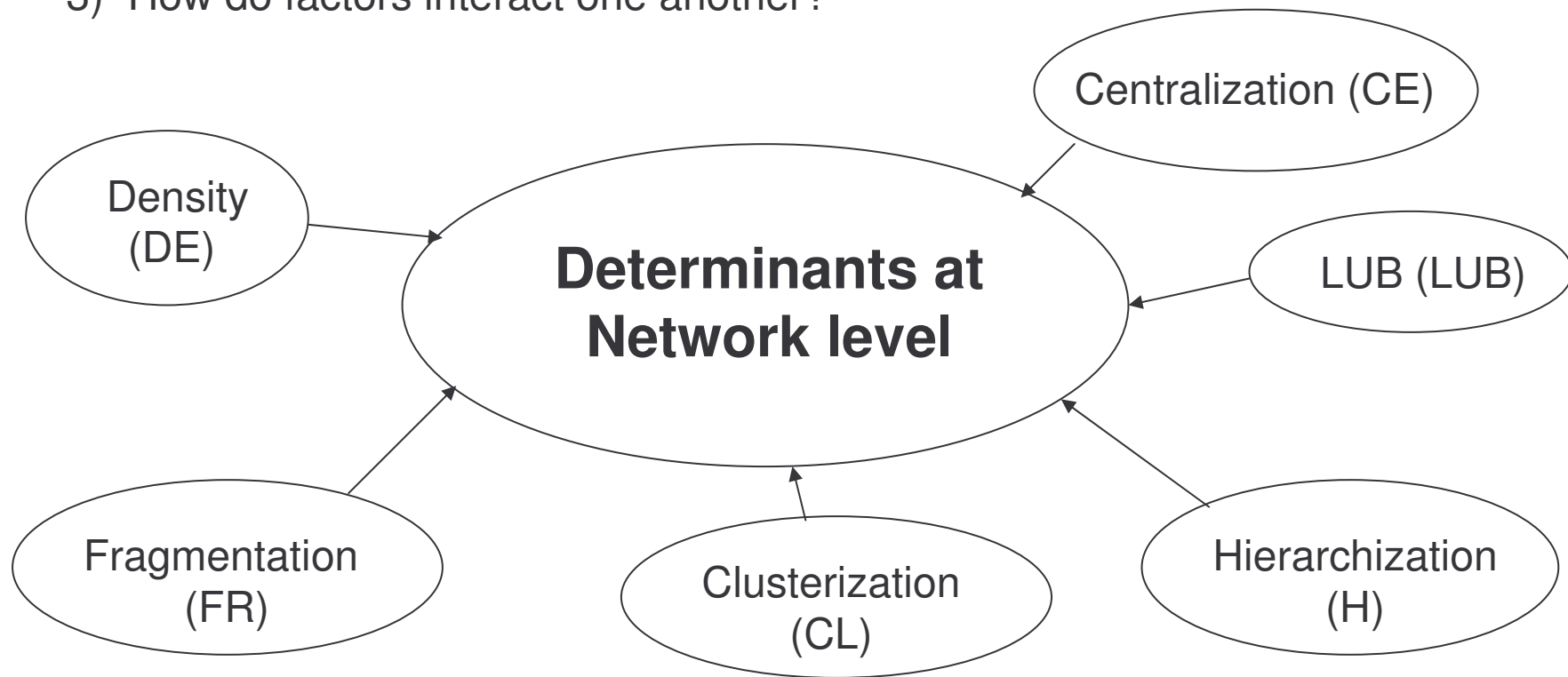

Determinants of the interdependence degree at both dyadic and network level

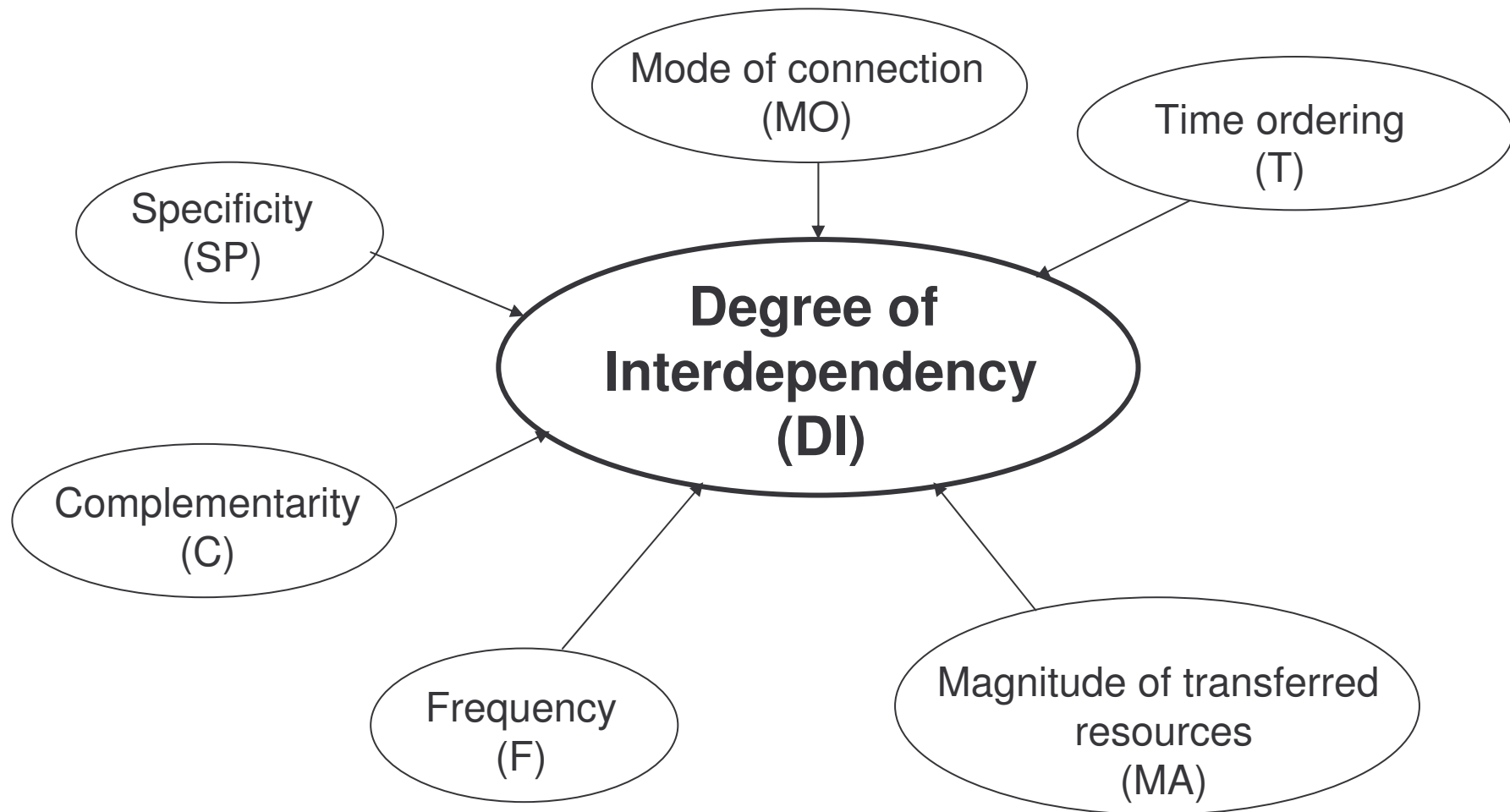

Modes of connection

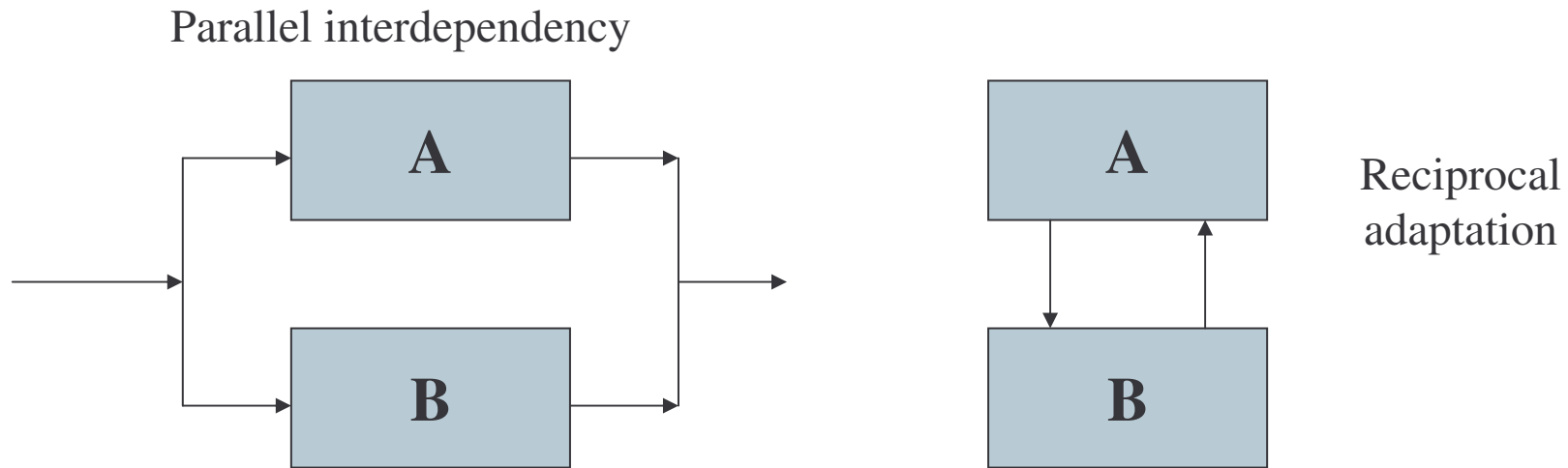

A categorization of the modes of connection

	linear	nonlinear
direct	sequential	reciprocal
indirect	parallel	

Complementarity: definitions

- A and B are complements of the same whole (task, product, etc.)
- A and B are relatively independent entities, but when combined they build a new entity or give advantages to both or one of the two
- Super-modularity: higher levels (quantity or quality) of A increases the efficiency (return) of B

Current results

- Many but fragmentary and sometimes contradictory results reached in many disciplines by empirical research
- Most of them do not focus or isolate a specific determinant
- Methodological and conceptual diversity hinder comparison of results

Methodologies

- Computational simulation models appear to be the best candidates for these types of analysis
- They allow to control variables and to find emergent rather than imposed solutions
- Many models have been recently built and others are under construction
- Specifically finalized to contribute to interdependence theory Biggiero & Sevi (2007) built a simulation model to analyze the effects of modes of connection and the moderating role of size, task complexity, and free riding